



## Smoke Detector with Transmitter Models 301/302

### Description:

The Models 301/302 are self-contained photoelectric type smoke detectors with an integral transmitter. The model 301 has a sounder and the model 302 does not. The detectors comply with UL 268 and are designed to provide open area protection. The transmitter is fully supervised for tamper, low battery, chamber sensitivity and RF signal integrity. The internal sounder in the model 301 can also be turned on remotely by the FACP. The smoke detector is powered by a single 3 volt lithium battery as listed under the specifications section of this manual and the label on the product. The Models 301/302 are intended to be used with CWSI Fire Alarm Control Panels. Refer to the FACP manual for compatibility details.

**IMPORTANT:** Smoke detectors must be tested and maintained regularly following NFPA 72 requirements. At a minimum, cleaning should be performed annually.

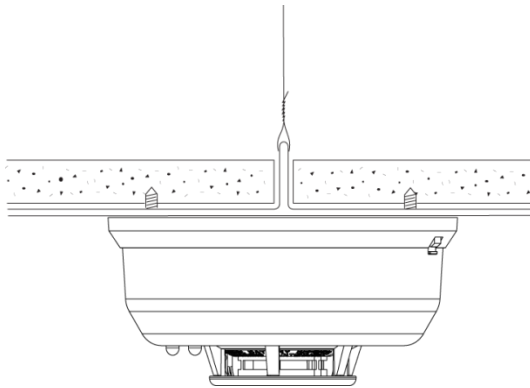
### Programming:

The 301/302 must be enrolled into the FACP before installing the device. **The Model 301/302 will not report Alarms, Supervisory or trouble signals unless it is enrolled into the control panel.** The smoke detector can be enrolled at the control panel or any enrolled repeater. Place the FACP in enrollment mode then install the battery in the smoke detector observing polarity. The model 301/302 serial number will be displayed on the FACP. Refer to the control panel installation instructions for further details on enrollment and transmitter programming options. After the model 301/302 is enrolled, remove the battery and reinstall it only at the transmitters intended mounting location.

### Installation:

Select an accessible location that is not prone to tampering or accidental damage. **The Model 301/302 must be installed and maintained in accordance with the National Fire Protection Association's Standards (NFPA), the National Electrical Code and all local fire and electrical requirements.** The mounting surface should be relatively flat and capable of accepting screws or anchors. The smoke detector is to be installed in an indoor dry location. Exposure to weather or corrosive conditions may damage the unit. Smoke detectors are not to be used with detector guards unless the combination has been evaluated and found suitable for that purpose. **Perform the signal test described in this manual prior to and after permanently mounting the unit.** **Note:** If the detector is mounted to a removable ceiling tile, the tile must be secured with the appropriate fasteners to prevent tile removal or mount the detector across a ceiling panel support as shown in figure 1. First install the mounting bracket using the screws supplied. Install the battery in the battery holder. The polarity is marked on the holder. Attach the detector to the bracket by turning the detector in a clockwise direction until it clicks into place. Wait for the green and red LED's to indicate standby condition (green blinks every 10s and red off) then perform the signal test and fully test the unit for alarm as described in **Alarm Testing**.

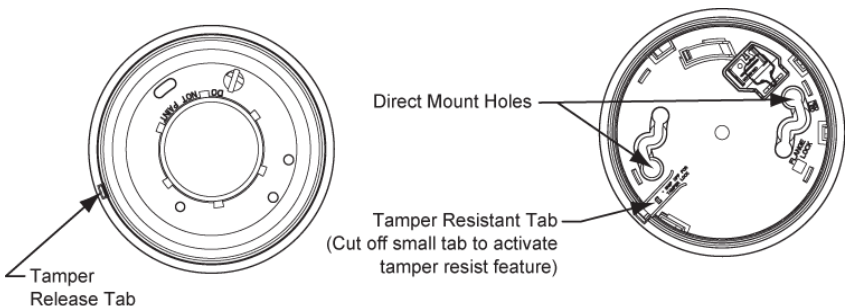




*Figure 1 Proper Mounting to Ceiling Tile*

**Tamper-Resistant Feature**

The smoke detector includes a tamper-resistant feature that prevents removal from the mounting base without the use of a tool. To engage the tamper-resistant feature, cut the small plastic tab located on the mounting base (Figure 2), and then install the detector. To remove the detector from the base once it has been made tamper resistant, use a small screwdriver to depress the square tamper release tab, located on the skirt of the mounting base, and turn the detector counterclockwise.



*Figure 2 Tamper Resistant Feature*

**Cautions:**

1. Make sure the battery is firmly installed in the smoke detector battery compartment.
2. The unit must be secured tightly to the wall, so as to not be dislodged.
3. Test the unit after any service, battery change or as often as local or national codes dictate.

**Do NOT Install Detectors in the Following Areas:**

- In or near areas where particles of combustion are normally present such as kitchens; in garages; near furnaces, hot water heaters, or gas space heaters.
- In very cold or very hot areas.
- In wet or excessively humid areas, or next to bathrooms with showers.
- In dusty, dirty, or insect-infested areas.
- Near fresh air inlets or returns or excessively drafty areas.

Consult NFPA 72, the local Authority Having Jurisdiction (AHJ), and/or applicable codes for specific information regarding the spacing and placement of smoke detectors. Refer to technical bulletin part number CWSI-IM-300-TB-Rev C for more information.

**Operation:****Led status indicators and Sounder**

The 301/302 detectors are equipped with two LED's status indicators and a sounder\* to provide local visual and audible indication of the detector's status. The table below explains the LED and sounder functions.

**LED Status and Sounder Operation**

Condition	Green LED	Red LED	Sounder*	Transmitted Signal to FACP
Power up	Blink every 5s for 20s	Blink every 5s for 20s	Off	None
Standby	Blink every 10s	Off	Off	Test (check in) every 90s
Alarm	Off	On Steady	Temporal pattern	Alarm
Test Switch Pressed (normal standby)	Off	On Steady	Temporal pattern	None
Test Switch pressed (in low batt)	Off	Blink every 45s	Silenced for 12 hours	Low Battery every 90s
Test Switch pressed (in alarm)	Off	On Steady	Silenced for 5 minutes	Alarm every 60 seconds
Maintenance or Fault	Off	Blink every 5s	Off	Maintenance Required Trouble Every 90s
Hardware Fault	Off	Blink every 5s	Off	Hardware Fit
Tamper	Blink every 10s	Off	Off	Tamper Trouble Every 90s
Low Battery	Off	Blink every 45s	Chirp every 45s after LED blinks for 2 days	Low Battery Trouble Every 90s

*Table 1***Alarm Operation:**

When the detector senses smoke the Green LED extinguishes, the Red LED turns on steady, the internal sounder\* turns on in the temporal pattern and the following occurs:

1. An initial alarm signal is transmitted.
2. A 60 second delay occurs. If during this delay the alarm condition is reset, a restore signal is sent ending the alarm cycle.
3. The continued alarm condition causes a repeat alarm transmission.

\*Except on the model 302.

4. Another 60 second delay as in step 2 occurs.
5. Step 4 repeats at 60 second intervals until reset.

**Tandem Sounder Feature Model 301 only**

The model 301 can be installed in living and common areas however when used in common areas do not program the tandem feature. The model 301 allows the smoke detectors piezo sounder to be turned on or off in tandem with an RF command signal from the FACP. This enables an installation to be programmed so that when an alarm is received from any smoke detector sensing smoke the FACP can activate the sounder in one or more smoke detectors that have not sensed smoke. When activated, the sounder

will turn on in the temporal pattern. **Note: Only the smoke detector sensing smoke will transmit an alarm signal.** This feature must be programmed into the FACP to function. Refer to the FACP manual for additional information and programming instruction. If the detector is in alarm due to smoke detection the tandem silence signal from the control panel will not silence the sounder. If the detector is in alarm due to smoke detection and it receives the tandem on signal the sounder will remain active even if smoke clears from the chamber. A tandem silence signal will be required to turn off the sounder.

### Alarm Testing

Detectors must be tested after installation and following maintenance or battery replacement. **NOTE: Before testing, notify the proper authorities that maintenance is being performed and the system will be temporarily out of service.** Place the FACP in test to prevent any unwanted alarms. Perform both A and B below to properly test the 301/302 detector. If a detector fails any of the tests below, it should be cleaned as outlined in the Maintenance section. If the detector still fails, it should be replaced.

#### A. Test Switch

Note: This test will only function if the detector is operating within its proper sensitivity limits and is not in a low battery condition.

The purpose of this test is to check the functionality of the circuitry. It **will not** cause an alarm signal to be transmitted.

1. An opening for the recessed test switch is located on the detector housing. (Figure 3)
2. Insert a small screwdriver or allen wrench (0.18" □ max.) into the test switch opening; push and hold for 5 seconds then release.
3. If the detector is within the listed sensitivity limits, the following will occur:
  - a. The green LED turns off.
  - b. The red LED turns on steady.
  - c. The sounder activates with the temporal pattern.\*
4. Perform step B below.

#### B. Smoke Entry Test

**Note:** This test **will** cause an alarm signal to be transmitted. Wait at least two minutes after power up before performing this test.

1. Hold a smoldering punk stick or cotton wick at the side of the detector and gently blow smoke through the detector until the unit alarms. Canned aerosol is also an acceptable method
2. Verify the alarm signal was received at the control panel.

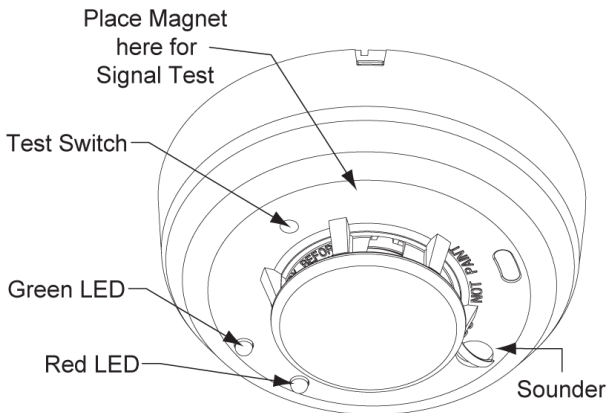
\*Except on the model 302

3. If both test A+B pass, remove the panel from test mode and notify the proper authorities when the system is back in service.

### Sensitivity Testing

**Note:** Wait at least two minutes after power up before performing the sensitivity test.

To measure the detector sensitivity use System Sensor model SENS-RDR Infrared Sensitivity Reader tool. Refer to the instruction manual of the model SENS-RDR (D100-98-00) for proper use.



*Figure 3 LEDs, Sounder, Test Switch and Signal Test Locations*

**Signal Test:**

The test must be performed while the smoke detector is held in its intended mounting location. Install a battery in the smoke detector. Initiate the test by placing a strong magnet on the smoke detector housing at the location shown in figure 3. The model 301/302 piezo sounder will beep once. A delay of up to 15 seconds will occur followed by either one or two beeps. One beep indicates an unacceptable location and two beeps indicate an acceptable location. If only one beep is heard then relocate the model 301/302 mounting position closer to the nearest repeater or control panel and perform the test again. Continue this procedure until 2 beeps are achieved. Do not mount the smoke detector unless 2 beeps are heard when performing 5 consecutive signal tests. This test **must** be performed before and after transmitter installation. Note: A CWSI model AR-3(A), AR-5 repeater or CWSI FACP must be powered up, installed and enrolled before running this test.

**Test Switch Functions:**

This switch has multiple functions and is located in an opening on the detector housing as shown in figure 3. To activate the switch insert a small screwdriver or allen wrench (0.18" max.) into the test switch opening; push and hold for 5 seconds. Pressing this switch will not cause an alarm at the control panel.

The functions of the Test Switch are:

1. Test the functionality of the detectors circuitry when pressed while the detector is in standby.
2. Silence the low battery chirp for 12 hours if pressed during low battery.
3. Silence the detector sounder for 5 minutes if pressed anytime while the sounder is turned on in the temporal pattern.

**Low battery:**

The model 301/302 smoke detector tests for a low battery condition once every 65 minutes. The battery voltage has to be at or below 2.7V nominally for two consecutive low battery tests before a low battery trouble condition is transmitted. When a low battery is detected the green LED will turn off, the red LED will blink every 45 seconds and a low battery trouble signal will be transmitted and repeated every 90 seconds. Once the low battery condition is present for 2 days, the piezo sounder will begin to chirp once every 45 seconds\*. This gives the service person time to replace the battery prior to audible notification. The low battery trouble signal will be transmitted and the piezo sounder will chirp for an additional 7 days. Pressing the smoke detector test button will silence the sounder chirp for 12 hours however the low battery trouble signal will continue to be transmitted every 90 seconds. Where more than one type of trouble exists, all will be

repeated in increments of 90 seconds. Always replace the battery with a new one. Refer to the Battery Installation and Replacement section for instructions on battery replacement.  
\*Except model 302

### **Battery Installation and Replacement:**

**Warning: Always install a new battery of one of the approved types as listed in the Specifications section of this manual and the product label.** When a battery is first inserted, a low battery test is performed. If the battery passes the test, the LED's should indicate normal standby. If the battery does not pass this test, the unit gives no indication of operation and the LEDs do not blink at all and a fresh battery should be installed.

### **To replace the battery:**

1. Place the FACP in Test mode to prevent any unwanted alarms.
2. Remove the detector from its mounting base by twisting the detector counterclockwise. Remove the battery and dispose of properly. If the Tamper Resistant feature was implemented during installation then follow the instructions under that section for removing the detector.
3. To insure proper power down sequence, wait a minimum of 20 seconds before installing a new battery.
4. Install a new approved 3 volt lithium battery in the battery compartment following the polarity diagram inside the compartment. A power up reset trouble signal should be indicated on the FACP upon installation of the new battery. A tamper trouble will also be indicated on the FACP if the smoke alarm is not attached to the base.
5. Reinstall the smoke detector onto the mounting base by turning the detector clockwise.
6. The LED's should indicate Power up and then Normal Standby conditions as shown in the LED status and sounder table.
7. Test the detector for alarm operation s described in the **Alarm Testing** section of this manual.
8. If the detector does not function as described in items 6+7 then start over at step 2. If it still doesn't operate correctly then replace the entire unit.
9. Remove the panel from test mode.

### **Tamper:**

The Models 301/302 contain a built in contact that will cause a tamper signal to be transmitted if the detector is removed from its mounting position. Upon detector removal, a tamper signal is transmitted and repeated every 90 seconds until the detector is mounted on its base. Where more than one type of trouble exists, all will be repeated in increments of 90 seconds. Note: This trouble is self-restoring on CP-3500D and newer FACP's.

### **Power Up Reset:**

The Models 301/302 will report this trouble when first powered up. This is normal. If a power up reset occurs anytime after the initial indication then the transmitter is malfunctioning. Replace the unit.

### **Test Failure:**

The Models 301/302 transmit a periodic test signal. This trouble condition will be displayed within 200 seconds on the FACP if it does not receive the test transmission. The detector may be out of reception range of a repeater or FACP or the detector may have an internal problem. Perform the signal test described in this manual to determine if there is a reception problem. Note: This trouble is self-restoring on CP-3500D and newer FACP's.

### Hardware Fit:

The Models 301/302 monitor the integrity of the communications between the smoke detector board and the RF transmitter board internal to the smoke detector. A Hardware Fit trouble will be displayed on the FACP if there is a failure with communications between the two boards. If this occurs replace the smoke detector.

### Maintenance / Fault:

The Models 301/302 contain circuitry that allows the detector to automatically adjust its sensitivity back to the factory setting when it becomes more sensitive due to contaminants settling in its chamber. If the sensitivity has shifted outside the listed limits the Green LED will extinguish, the Red LED will flash every 5 seconds and a maintenance required signal will be sent and repeated every 90 seconds until the condition is corrected. Perform maintenance on the detector as described in this manual. If the problem persists, replace the detector.

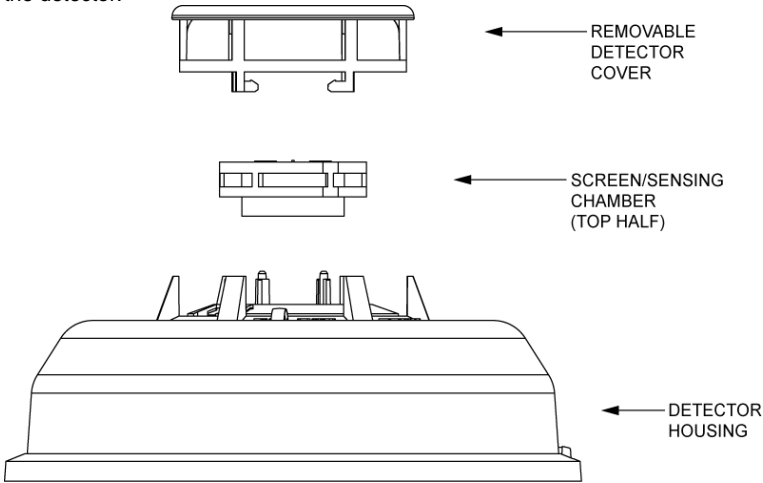


Figure 4 Removing Screen/Sensing Chamber

### Maintenance

Perform maintenance yearly or whenever a Maintenance Req. Trouble signal is indicated.

**Warning: Never remove the tamper proof screws attaching the detector cover to the chassis containing the circuit boards. The chamber is accessible without removing the cover.**

NOTE: Before performing maintenance on the detector, notify the proper authorities that maintenance is being performed and the system will be temporarily out of service. Place the control panel in test mode to prevent any unwanted alarms.

The battery must be removed from the detector before performing maintenance of any kind.

1. Place the FACP in Test mode to prevent any unwanted alarms.
2. Remove the detector by turning counterclockwise and remove the battery.
3. To insure proper power down sequence, wait a minimum of 20 seconds before removing chamber top.
4. Remove the chamber cover by turning it counterclockwise.
5. Vacuum the chamber cover or use canned air to remove any dust or debris.

6. Remove the top half of the screen/sensing chamber by lifting straight up. (Figure 4)
7. Vacuum or use canned air to remove any dust or particles that are present on both chamber halves.
8. Replace the top half of the screen/sensing chamber by aligning the arrow on the screen/sensing chamber with the arrow on the housing. Press down firmly until the screen/sensing chamber is fully seated.
9. Replace the chamber cover by placing it over the screen/sensing chamber and turning it clockwise until it snaps into place.
10. Reinstall the battery.
11. Reinstall the smoke detector onto the mounting base by turning the detector clockwise.
12. Test the detector for alarm operation as described in the **Alarm Testing** section of this manual.
13. If the detector does not function as described in item 10 then start over at step 2. If it still doesn't operate correctly then replace the entire unit.
14. Remove the panel from test mode.



**Specifications:**

- Battery Type: 3 Volt Lithium; Duracell DL123 / Ultra123.
- Battery Life: 12 Months Minimum
- Battery Replacement: Upon Low battery report and/or during annual maintenance.
- Average Standby Current: Model 302 32.8ua Model 301 71.5ua
- Average Alarm Current: Model 302 35ma Model 301 36ma
- Tamper Switch: On base
- Sounder: 85db at 10' temporal pattern. Model 301 only
- Reset: Automatic
- Sensitivity: 2.0% nominal
- Low battery threshold: 2.7V
- Operating Temperature Range: 32°F to +100°F.
- Operating Humidity Range 0 to 95% RH.
- Testing: Follow this manual and NFPA 72 or local requirements.
- Transmission: In compliance with FCC part 15
- Test Transmission: Every 90 seconds.
- Mounting base diameter 5.30"
- Weight 6.4 oz.

**FCC Statement**

Important: Any changes or modifications not expressly approved by the party responsible for compliance could void the user's authority to operate the equipment

This device complies with part 15 of the FCC Rules. Operation is subject to the following two conditions: (1) This device may not cause harmful interference, and (2) this device must accept any interference received, including interference that may cause undesired operation.

# Disclaimer

The information contained in this document is believed to be accurate and reliable at the time of printing. Known corrections or omissions may be found on errata sheets included in the various product manuals. However, CWSI a Tyco Fire & Security GmbH Company (CWSI), may not be held accountable for errors or omissions in this or other CWSI publications. No license is granted by implication or otherwise under any patent rights of CWSI. Applicable terms and conditions can be found at [http://tycofsbp.com/TFPPTerms\\_of\\_Sale/TFPPTerms\\_of\\_Sale.pdf](http://tycofsbp.com/TFPPTerms_of_Sale/TFPPTerms_of_Sale.pdf)